

Contents

	Page
1. DIMENSIONS	3
2. GENERAL CHARACTERISTICS	5
3. BK 117 C-1 - STANDARD AIRCRAFT CONFIGURATION	7
4. WEIGHT SUPPLEMENT OF OPTIONAL EQUIPMENT	9
5. FUELS SPECIFICATIONS	15
6. RADIO COMMUNICATION AND NAVIGATION EQUIPMENT	17
6.1 STANDARD AVIONIC EQUIPMENT	17
6.2 AVIONIC PACKAGES	17
6.3 HEADSETS/HELMETS	18
6.4 VFR - PACKAGES	19
6.5 IFR - PACKAGES	20
6.6 ASSOCIATED AVIONIC PACKAGE EQUIPMENT	26
	27
7. MAIN PERFORMANCE	29

intentionally left blank

1. DIMENSIONS

External Dimensions

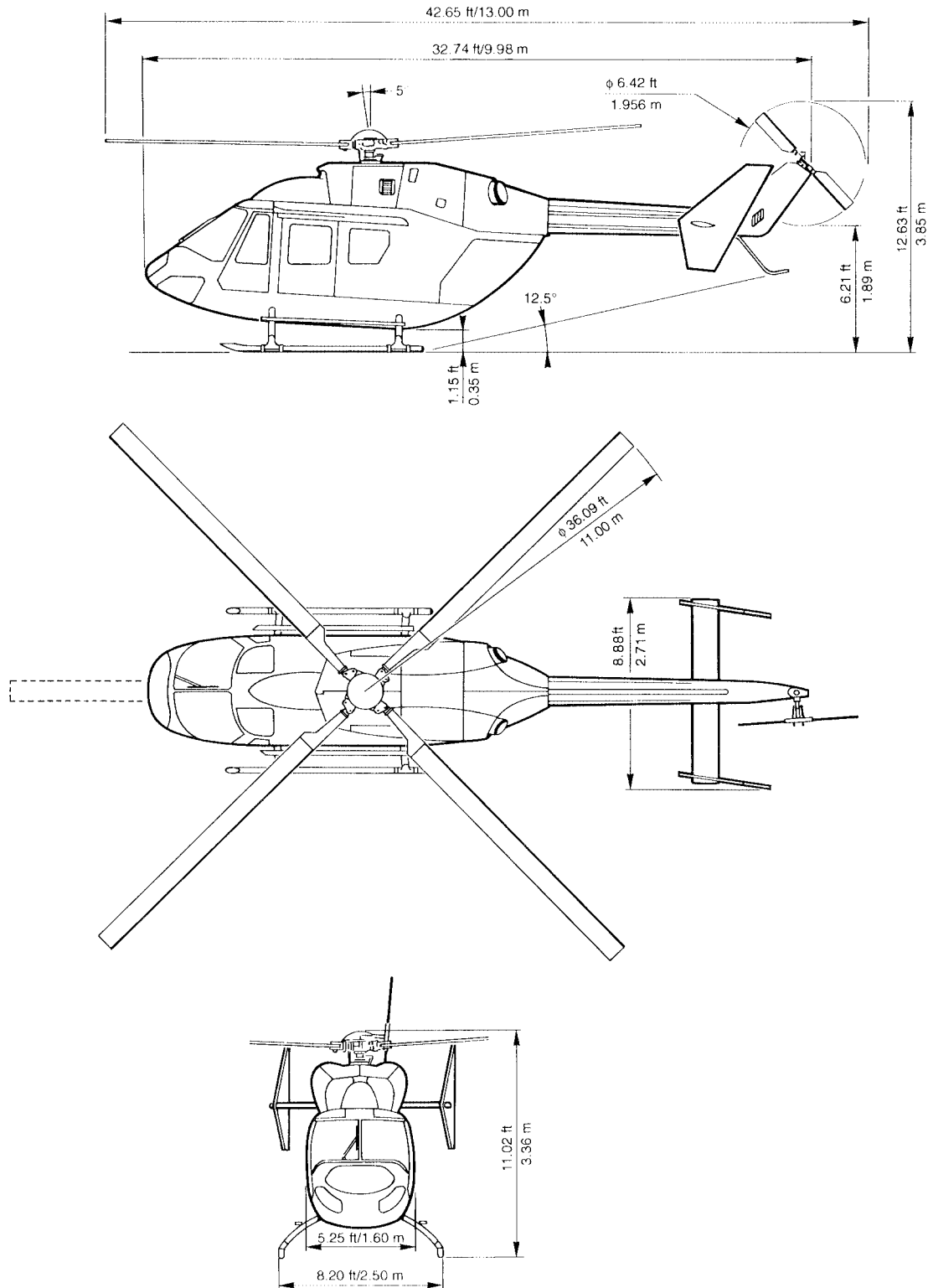

Internal Dimensions

Shoulder height

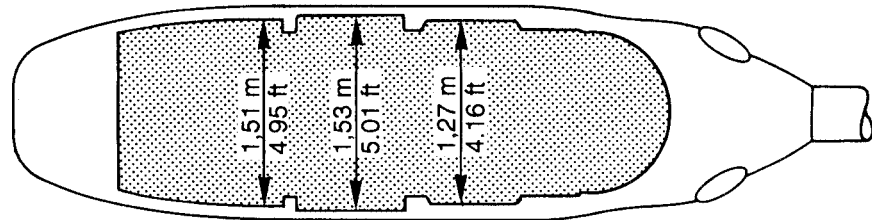

Floor level

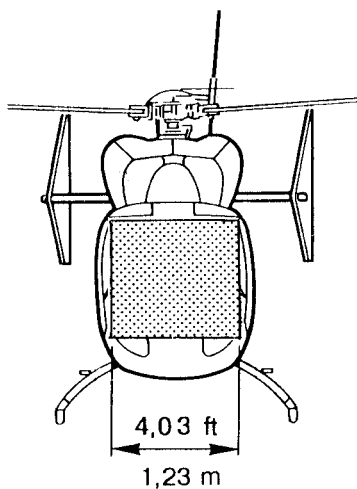
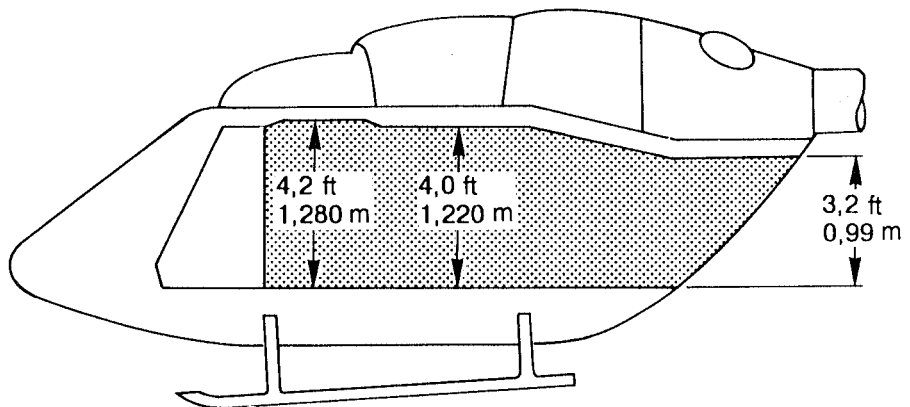
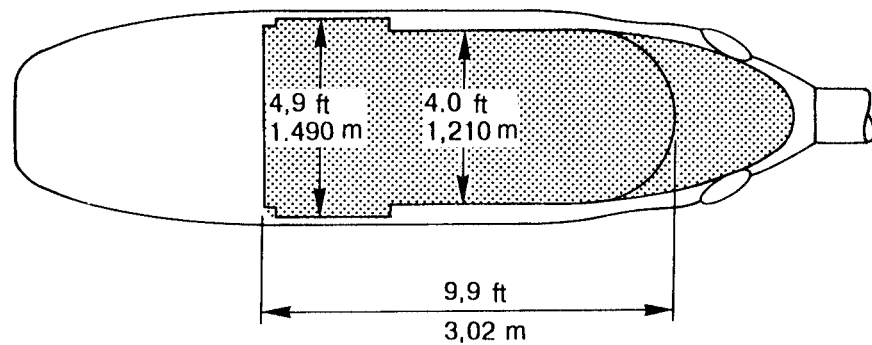

CABIN	
Area	3.70 m ² 39.82 ft ²
Volume	5.00 m ³ 176.57 ft ³

2. GENERAL CHARACTERISTICS

LAY-OUT

- Passenger transport : 1 or 2 pilots + 7 or 6 passengers in standard "executive" version
1 or 2 pilots + 10 or 9 passengers in "utility" version
- Casualty evacuation : 1 or 2 pilots + 2 stretcher-patients + 3 seats for doctor, paramedic, medical attendants or nurses

WEIGHTS

- Empty weight, standard sales aircraft :
(including engine oil and non usable fuel)
- Useful load :
- Maximum take-off weight :
- Maximum take-off weight with external sling load :
- Maximum external sling load :

	kg	lb
Empty weight, standard sales aircraft : (including engine oil and non usable fuel)	1,765	3,891
Useful load :	1,585	3,494
Maximum take-off weight :	3,350	7,385
Maximum take-off weight with external sling load :	3,500	7,716
Maximum external sling load :	1,500	3,307

POWER PLANT : 2 TURBOMECA ARRIEL 1E2 turbine engines

Engine ratings (thermodynamic limits), in standard atmosphere, at sea level :

- One Engine Inoperative OEI 2,5 min power
- One Engine Inoperative OEI unlimited power
- Take-off power
- Maximum continuous power

	kW	ch	shp
One Engine Inoperative OEI 2,5 min power	574	780	770
One Engine Inoperative OEI unlimited power	550	748	738
Take-off power	550	748	738
Maximum continuous power	516	702	692

FUEL CAPACITIES

(assumed fuel density 0,8 kg/l)

- Standard tanks
- Optional fuel tanks
 - ♦ Long range fuel tank
 - ♦ Extended range fuel tank
 - ♦ External fuel tank, LH
 - ♦ External fuel tank, RH

	litres	US gal.	kg	lb
Standard tanks	697	184	558	1,230
Optional fuel tanks				
♦ Long range fuel tank	200	53	160	353
♦ Extended range fuel tank	200	53	160	353
♦ External fuel tank, LH	150	39.6	120	265
♦ External fuel tank, RH	150	39.6	120	265

intentionally left blank

3. BK 117 C-1 - STANDARD AIRCRAFT CONFIGURATION

GENERAL

Practical and modern fuselage comprising cockpit and cabin/cargo compartment
 Tail boom with vertical and horizontal stabilizer and endplates
 Tail skid
 Non-retractable skid type landing gear with skid protectors and long boarding steps

Built-in footsteps (2 at each side) for access to transmission deck
 Two hinged rear clam shell doors
 Single colour exterior painting

CABIN

1 flat, unobstructed cabin floor with inserts for some optionals
 2 removable, longitudinally and vertically adjustable pilot and copilot seats with head rest, lap belt and adjustable shoulder harness with automatic locking system
 6 upholstered forward and aft passenger bench seats with head rest and lap and shoulder safety belts with automatic locking system
 2 jettisonable hinged cockpit doors with ventilating windows
 2 jettisonable sliding doors with ventilating windows
 Interior panelling and sound insulation
 Floor covering
 Tie-down rings on cabin floor

Ram-air and electrical ventilating system
 Dome lights in cockpit and cabin compartment
 1 utility light in the cockpit
 Flight controls, pilot's side
 Windscreen wiper, pilot's side
 Engine controls
 Rotor brake control lever
 1 first aid kit
 1 portable fire extinguisher
 1 electric torch
 Map cases on glare shield and center console (LH and RH each) and at both cockpit doors
 Holder for head sets

INSTRUMENTS

1 airspeed indicator
 1 encoding barometric altimeter
 1 instantaneous vertical speed indicator
 1 4" artificial horizon
 1 3" stand-by artificial horizon
 1 gyro magnetic heading system
 1 horizontal situation indicator
 1 magnetic compass
 1 ambient air thermometer
 1 clock
 1 triple tachometer (rotor and two N2)
 2 tachometers for N1/DN1
 2 turbine outlet temperature indicators (TOT)
 1 dual torque indicator
 2 engine oil pressure/temperature indicators
 1 dual transmission oil pressure indicator

1 transmission oil temperature indicator
 1 triple fuel quantity indicator
 2 hydraulic pressure indicators
 1 service hourmeter
 1 dual ammeter
 1 dual voltmeter
 1 main switch panel
 1 yaw CSAS control panel
 1 annunciator panel
 2 master caution lights
 1 engine fire control panel
 1 mast moment indicator
 1 audio warning for rotor/engine rpm
 2 engine overspeed failure caution lights
 1 VARTOMS caution light
 Spare space for radar screen and radio communication/navigation equipment

POWER PLANT SYSTEM

- | | |
|---|--|
| <ul style="list-style-type: none"> 2 TURBOMECA ARRIEL 1E2 turbine engines each developing 574 kw (770 shp - 780 ch) maximum emergency (2,5 min.) power complete with starting, fuel supply and control systems 1 fuel system with 3 main tanks and 2 supply tanks providing a total usable capacity of 697 liters (558 kg) and 2 independent supply systems | <ul style="list-style-type: none"> 1 oil cooling and lubrication system for the main transmission 2 independent oil cooling and lubrication systems of the engines 1 fire detection and extinguishing system 2 exhaust and ejector ducts 1 automatically controlled variable rotor speed system 1 automatic torque matching system |
|---|--|

TRANSMISSION SYSTEM

- | | |
|---|---|
| <ul style="list-style-type: none"> 1 main transmission including a two section housing, a two stage reduction gear, an independent redundant lubrication system and some monitoring sensors 2 free wheel assemblies in the engine input drive | <ul style="list-style-type: none"> 1 tail rotor drive shaft 1 rotor brake system 1 intermediate transmission 1 tail rotor transmission with splash lubrication, magnetic plug and oil level sight gauge |
|---|---|

ROTORS AND FLIGHT CONTROLS

- | | |
|---|--|
| <ul style="list-style-type: none"> 1 hingeless main rotor (System Bölkow) with 4 glass and carbon fibre reinforced blades with erosion protection strip 1 semi-rigid tail rotor with 2 twisted glass fibre reinforced blades of new technology with erosion protection strip 1 Main rotor blade tip painting with yellow paint | <ul style="list-style-type: none"> 1 flight control system with dual hydraulic boost system for cyclic and collective blade control of the main rotor and a yaw control and stability augmentation system for the tail rotor Special main rotor tip painting |
|---|--|

ELECTRICAL SYSTEM

- | | |
|---|--|
| <ul style="list-style-type: none"> 2 starter/generators (2 x 200 A/28 V.D.C.) 1 nickel-cadmium battery, 24 V, 25 Ah consisting of 20 cells 1 external power unit receptacle 1 AC inverter 1 internal lighting with adjustable dimming for all instruments, switches and circuit breakers | <ul style="list-style-type: none"> 1 emergency exit lighting system 1 anti-collision light (red flashing) 3 position lights 1 retractable landing light (450 w) 2 heated pitot tubes and static ports |
|---|--|

HYDRAULIC SYSTEM

- | | |
|---|---|
| <ul style="list-style-type: none"> 2 independent hydraulic systems (1 operating and 1 stand-by system) for flight controls and yaw control and stability augmentation system | <ul style="list-style-type: none"> 2 hydraulic pumps driven by the main transmission |
|---|---|

GROUND HANDLING, MISCELLANEOUS (weight not included in the standard helicopter empty weight)

- | | |
|---|---|
| <ul style="list-style-type: none"> 2 ground handling wheels 1 basic tie down kit 2 pitot tube covers 1 engine air inlet cover | <ul style="list-style-type: none"> 2 ejector duct covers oil drain hoses 1 set of keys |
|---|---|

4. WEIGHT SUPPLEMENT OF OPTIONAL EQUIPMENT
Cockpit, Cabin and Cargo Compartment Equipment

		Weight supplement			
		complete installation, including fixed parts		fixed parts, only	
		kg	lb	kg	lb
BK-015	Hand hold to ease cabin boarding	1.0	2.2	-	-
BK-016	Rear located arrangement of the aft passenger bench seat (complete with modified rear standard pax bench seat)	1.5	3.3	0.2	0.4
BK-017	Utility seats, complete	47.4	104.5	9.9	21.8
BK-017b	Utility bench seat, fwd	12.5	27.6	-	-
BK-017c	Utility bench seat, LH	12.5	27.6	-	-
BK-017d	Utility bench seat, RH	12.5	27.6	-	-
BK-020f	Sound insulating wall	7.7	17.0	0.5	1.1
BK-021c	Additional one-stroke function for dual windscreen wiper system	0.3	0.7	-	-
BK-027a	Custom sound proofing kit, (version A)	8.3	18.3	-	-
BK-027b	Custom sound proofing kit, (version B, incl. version A)	22.1	48.7	-	-
BK-028	Multi purpose cabin floor inserts	0.5	1.1	-	-
BK-062	Chip detector indication for intermediate and tail rotor transmission with quick disconnectable plugs	0.2	0.4	-	-
BK-072	Cabin speakers	2.9	6.4	-	-
BK-183	Second portable fire extinguisher	2.5	5.5	-	-
BK-190a	Rear clamshell door window, LH	1.0	2.2	-	-
BK-190b	Rear clamshell door window, RH	1.0	2.2	-	-
BK-194	Tinted cockpit roof windows	0.9	2.0	-	-
BK-195	Tinted passenger compartment windows	-	-	-	-

		Weight supplement			
		complete installation, including fixed parts		fixed parts, only	
		kg	lb	kg	lb
BK-196a	Tinted double pane cabin windows with ventilating sliding window	5.8	12.8	-	-
BK-241	Executive kit including: Extended interior panelling and painting Additional boarding step LH and RH Hand hold for boarding LH and RH 2 retractable coat hooks Headset holders in the cockpit	4.0	8.8	-	-
BK-242	Extended interior panelling and painting	0.8	1.8	-	-
BK-277	Cockpit/cabin separating curtain	1.4	3.1	0.4	0.9
Heating and Ventilation Equipment					
BK-031	Bleed air heating system including windshield defogging system	20.0	44.1	-	-
BK-032a	Combined cabin roof electrical ventilating (incl. blower) and illumination system	4.7	10.4	-	-
BK-032c	Cabin roof electrical ventilating system for EMS	3.8	8.4	-	-
BK-033a	Air conditioning/cooling system, (vapour cycle type), for cockpit/passenger cabin	60.4	133.2	-	-
BK-033c	Air conditioning/cooling system (vapour cycle type), for cockpit/EMS cabin layout	60.4	133.2	-	-
Landing Gear and Associated Equipment					
BK-051	Emergency floats	89.2	196.6	10.9	24.0
BK-052	Snow skids	23.1	50.9	0.2	0.4
BK-053	Settling protectors	10.4	22.9	0.1	0.3
BK-055	High skid landing gear (in addition to standard landing gear)	+39.3	+86.6	-	-

Engine Related Equipment

BK-198	Pulsed chip detectors (fuzz burners) for the engines
BK-199a	Scavenge oil filter (Facet)
BK-200	Engine compressor washing device

Landing and Search Lights incl. Illumination Equipment

BK-091b	Landing light, retractable (450 W), at the RH forward landing gear cross tube
BK-092	2nd Landing light, fixed (250 W), integrated in the nose shell section
BK-092a	2nd Landing light, fixed (250 W), at the LH forward landing gear cross tube
BK-092b	2nd Landing light, fixed (250 W), at the RH forward landing gear cross tube
BK-093	Landing and search light (450 W), integrated in the nose shell section (instead of the std. landing light)
BK-093b	Landing and search light (450 W) at the RH forward landing gear cross tube
BK-095	Flare system (without flares)
BK-097a	Tail flood light, (Version A)
BK-097b	Tail flood light, (Version B)
BK-165b	NVG compatible landing and search light, RH cross tube mounted
BK-205	Searchlight SX 16 front installation
BK-205d	Search light SX 16 with IR-filter, front installation, complete (2nd landing and search light is necessary)
BK-210	Anti-dazzle lights (storm lights)
BK-211	Flash lights (white strobe lights)

Weight supplement			
complete installation, including fixed parts		fixed parts, only	
kg	Lb	kg	lb
1.2	2.6	-	-
1.9	4.2	-	-
0.9	2.0	-	-
3.0	6.6	-	-
0.8	1.6	-	-
1.0	2.2	-	-
1.2	2.6	-	-
1.6	0.8	-	-
2.5	5.5	-	-
-	-	3.2	7.1
0.8	1.8	-	-
0.8	1.8	-	-
+0.5	+1.1	-	-
27.7	61.1	4.2	9.3
37.2	82.0	4.7	10.4
on request		-	-
1.9	4.2	-	-

BK-068f	Load hook retraction system
BK-171	Battery relocation
BK-202	External loudspeaker system <ul style="list-style-type: none"> ▪ with fwd installation of power amplifier ▪ with aft installation of power amplifier
BK-202d	Siren system for external loudspeaker system (type Wandel & Goltermann)
BK-203	External loudspeaker system (type NAT, 2 loudspeakers), including siren system
BK-206d	Litter (NATO-type)
BK-218	Sand filter system, complete

Special Mission Equipment

BK-160	NVG-compatible basic cockpit layout (std. instrumentation)
BK-172	40 Ah battery
BK-179	IFR-trainings screen
BK-204	Self-sealing feeder tanks
BK-217	Cold weather kit

Weight supplement			
complete installation, including fixed parts		fixed parts, only	
kg	lb	kg	lb
2.5	5.5	0.6	1.3
7.9	17.4	-	-
19.7	43.4	1.4	3.1
21.1	46.5	3.6	7.9
1.1	2.4	-	-
19.4	42.8	-	-
9.6	21.1	-	-
38.8	85.5	5.9	13.0
on request			
+11.0	+24.3	-	-
5.3	11.7	0.3	0.7
3.3	7.3	-	-
0.9	2.0	-	-

		Weight supplement			
		complete installation, including fixed parts		fixed parts, only	
		kg	lb	kg	lb
BK-243	One-hand latching system, rear clamshell doors	4.2	9.3	-	-
BK-245	Wire strike protection system (WSPS)	10.8	23.8	2.4	5.3
BK-275	Flight attendant/winch operator swivel seat	21.5	47.4	-	-
BK-290	Fire extinguishing bucket, type "Bambi 680 ltr"	50.5	111.3	0.5	1.1
BK-290c	Fire extinguishing bucket, type "Bambi 680 ltr" with "Sacksafoam" foam injection system	61.0	134.5	1.0	2.2
Communication/Navigation and Flight Control Equipment					
BK-170	Radar radome	3.6	7.9	-	-
BK-170b	Radar radome with battery relocation	9.8	21.6	-	-
BK-181	Avionic rack with ventilation	11.1	24.5	-	-
BK-188	Cockpit (IFR) storage kit (incl. second portable fire extinguisher)	4.5	9.9	-	-
BK-189	IFR chart holders for pilot and copilot	0.5	1.1	-	-
BK-214	Command and stability augmentation system (CSAS)	6.3	13.9	-	-
BK-215c	Digital Automatic Flight Control System (DAFCS), Autopilot (coupled FD)	40.1	88.4	-	-
BK-215d	Digital Automatic Flight Control System (DAFCS), Autopilot for DGAC-certification	44.0	88.8	-	-
BK-200	Cockpit Voice recorder Fairchild A 100	on request			
Handling and Picketing					
BK-041	Main rotor blade folding kit	13.7	30.2	0.7	1.5
BK-069	Tie down and covering kit	(22.7)	(50.0)	GSE equipment	
BK-076a	Lashing points	3.0	6.6	-	-

5. FUELS SPECIFICATIONS
PRIMARY FUELS

TYPE OF FUEL	NATO SYMBOL	SPECIFICATION				ANTI-ICE ADDITIVE
		USA	U.K.	CAN	FRANCE	
Kerosene-50 (AVTUR-FS II) JP-8	F 34	MIL-T-83 133 JP-8	D.ENG.RD 2453	-	AIR 3405-F-34	Yes
Kerosene-50 (AVTUR) JET A-1	F 35	ASTM-D-1655 JET A-1	D.ENG.RD 2494	2.3.23	AIR 3405-F-35	No
Kerosene	-	ASTM-D-1655 JET A	-	-	-	No
Wide-cut JP-4 (AVTAG FS II)	F 40	MIL-T-5624 JP-4	D.ENG.RD 2454	2.3.24	AIR 3407	Yes
Wide-cut JP-4 (AVTAG)	-	-	D.ENG.RD 2486	-	-	No
Wide-cut	-	ASTM-D-1655 JET B	-	-	-	No
High flash point kerosene JP-5 (AVCAT)	F 43	-	D.ENG.RD 2493	-	AIR 3404-F-43	No
High flash point kerosene JP-5 (AVCAT FS II)	F 44	MIL-T-5624 JP-5	D.ENG.RD 2452	-	AIR 3404-F-44	Yes

SECONDARY FUELS

TYPE OF FUEL	NATO SYMBOL	SPECIFICATION		
		U.S.A.	U.K.	FRANCE
Aviation fuel (AVGAS)	F 12	MIL-G-5572 Grade 80/87	-	AIR 3401 80/87
	F 18	MIL-G-5572 Grade 100/130	D.ENG RD 2485	AIR 3401 100/130
	F 22	MIL-G-5572 GRADE 115/145	-	AIR 3401 115/145
Motor car petrol Petrol for tanks	F 46	MIL-G-3056	DEF. 2401	DCEA/2DMT80

intentionally left blank

6. RADIO COMMUNICATION AND NAVIGATION EQUIPMENT

6.1 Standard Avionic Equipment

The following systems are included in all basic helicopter configurations as manufacturer`s standard:

- 4" Artificial Horizon, pilot GH 14-671
- Horizontal Situation Indicator, pilot KPI 552 (ALLIED SIGNAL)
- 3" Stand-by Horizon without battery pack AIM 510-1G
- Gyro Magnetic Heading System C 14 D
- Encoding Barometric Altimeter 5035 P2 P42
- Instantaneous Vertical Speed Indicator
- Airspeed Indicator
- Magnetic Compass
- Clock
- Ambient Air Thermometer
- Static Inverter PC 250

6.2 Avionic Packages

Following possible avionic packages according to LBA and FAA requirements are basically offered:

		Conventioanl	EFIS
SP-VFR	ALLIED SIGNAL Silver Crown	1	
	ALLIED SIGNAL Gold Crown	2	
DP-VFR	ALLIED SIGNAL Silver Crown	1 (with BK-064 a)	
	ALLIED SIGNAL Gold Crown	2 (with BK 064 a)	
DP-IFR	ALLIED SIGNAL Silver Crown	3	
	ALLIED SIGNAL Gold Crown	4	5
DP/SP-IFR with DAFCS	ALLIED SIGNAL Silver Crown	6	
	ALLIED SIGNAL Gold Crown	7	8

Comments:

- The numbers given in the matrix correspond to the different solutions described in the Avionic enclosure
- VFR is included in all solutions

NVG compatible avionic equipment versions can be offered on request.

6.3 Headsets/Helmets
Headsets

Manufacturer	Linear Wire	Spiral Wire	Low Imp.	High. Imp.	ANR	Type
HOLMBERG		•	•			90-04-08022-10
HOLMBERG		•		•		90-04-06025-10
ELNO	•		•			247 SP 165
ELNO	•			•		247 SP 167
DAVID CLARK		•	•			H 10-76
DAVID CLARK		•		•		H 10-56
DAVID CLARK		•		•	•	H 20-10HX
SENHEISER	•		•		•	HMDC 222
BOSE		•		•	•	011697

Helmets

Manufacturer	Linear Wire	Spiral Wire	Low Imp.	High Imp.	ANR	Type
GENTEX	•		•			SPH 5

6.4 VFR - Packages
**Minimum Items of Equipment for Single Pilot VFR Certification - Civil Use
(Allied Signal Silver Crown)**

Designation	Solution 1
VHF Nav/Comm. System	KX 165
Comm. Control System, 1 station	AS 3100-12 (BECKER)
Transponder	KT 71
2ea Radio Master Switch	Special ECD
Weight supplement	8.0 kg

For Dual Pilot VFR the optional (BK-64a) Dual Pilot Operation Kit is required

**Minimum Items of Equipment for Single Pilot VFR Certification - Civil Use
(Allied Signal Gold Crown)**

Designation	Solution 2
VHF AM/Comm. System	KTR 908/KFS 598 A
Comm. Control System (1 station) + Intercom Select Panel	AS 3100-12 (BECKER)
VOR/ILS/MB Navigation System with HSI	KNR 634 A / KFS 564 A / KA 35 A
Transponder	KXP 756 / KFS 576 A
2ea Radio Master Switch	Special ECD
Weight supplement	12.0 kg

For Dual Pilot VFR the optional (BK-64 a) Dual Pilot Operation Kit is required

6.5 IFR - Packages
**1. Minimum Items of Equipment for Dual Pilot IFR Certification - Civil Use
(with conventional instrumentation Allied Signal Silver Crown)**

Designation	Solution 3
VHF Nav/Comm System	KX 165
VHF Nav/Comm System, 2nd System	KX 165
Marker beacon	KR 21
Comm. Control System, 2 stations + Intercom Select Panel	BECKER AS 3100-12
Automatic Direction Finder (A.D.F.)	KR 87
Distance Measuring Equipment (D.M.E.)	KN 63 / KDI 572
Transponder	KT 71
Battery Pack for Stand-by Horizon	PS-835 C
2ea radio master switch	Special ECD
Weight supplement (without equipment kit)	26.2 kg

Note: Required equipment kit for dual pilot IFR-operations refer to para 6.6

2. Minimum Items of Equipment for Dual Pilot IFR Certification - Allied Signal Gold Crown (with conventional instrumentation)

Designation	Solution 4
VHF/AM Comm System	KTR 908 / KFS 598 A
VHF/AM Comm System, 2nd System	KTR 908 / KFS 598 A
Comm. Control System, 2 stations + Intercom Select Panel	AS 3100-12 BECKER
VOR / ILS / MKR Navigation System with CDI	KNR 634 A / KFS 564 A / KA 35 A / KI 204
VOR / ILS / MKR Navigation System, with CDI, 2nd System	KNR 634 A / KFS 564 A / KI 204
Automatic Direction Finder (A.D.F.)	KDF 806 / KFS 586 A
Transponder	KXP 756 / KFS 576 A
Distance Measuring Equipment (D.M.E.)	KDM 706 A / KDI 572 *)
Battery Pack for Stand-by Horizon	PS-835 C
2ea radio master switch	Special ECD
Weight supplement (without equipment kit)	36.5 kg

Note: Required equipment kit for dual pilot IFR-operations refer to para 6.6

*) HSI KPI 553 A instead of KPI 522 and KDI 572 can be chosen

**3. Minimum Items of Equipment for Dual Pilot IFR Certification - Civil Use
(with EFS 40, Allied Signal Silver Crown)**

Designation	Solution 5
EFS 40	SG 465 / 2 ED 511 A / CP 467 / SU 463
EFS 50, 2nd System	SG 465 / 2 ED 511 A / CP 467
VHF/AM Comm System	KTR 908 / KFS 598 A
VHF/AM Comm System, 2nd System	KTR 908 / KFS 598 A
Comm. Control System, 2 stations + Intercom Select Panel	AS 3100-12 BECKER
VOR / ILS / MKR Navigation System	KNR 634 A / KFS 564 A
VOR / ILS / MKR Navigation System, 2nd System	KNR 634 A / KFS 564 A
Automatic Direction Finder (A.D.F.)	KDF 806 / KFS 586 A
Transponder	KXP 756 / KFS 576 A
Distance Measuring Equipment (D.M.E.)	DMS 44 A
Battery pack for stand-by horizon	PS 835 C
2ea radio master switch	Special ECD
Weight supplement (without equipment kit)	56.0 kg

Note: Required equipment kit for dual pilot IFR-operation refer to para 6.6

**4. Minimum Items of Equipment for Dual/Single Pilot IFR Certification - Civil Use
(with AFCS and conventional instrumentation, Allied Signal Silver Crown)**

Designation	Solution 6
VHF NAV/Comm System	KX 165 / KI 204
VHF NAV/Comm System, 2nd System	KX 165 / KI 204
Comm. Control System, 2 stations + Intercom Select Panel	AS 3100-12 (BECKER)
Distance Measuring Equipment (D.M.E.)	KN 63 / KDI 572
Automatic Direction Finder (A.D.F.)	KR 87
Marker Beacon	KR 21
Transponder	KT 71
Radar altimeter	KRA 405 B / KNI 416
Battery pack for stand-by horizon	PS-835 C
2ea Vertical GYRO	VG 208 (B.F GOODRICH)
2ea radio master switch	Special ECD
Weight supplement (without equipment kit)	34.3 kg

Note: Required equipment kit for single/dual pilot IFR-operations refer to para 6.6

**5. Minimum Items of Equipment for Dual/Single Pilot IFR Certification - Civil Use
(Allied Signal Gold Crown)**

Designation	Solution 7
VHF AM / Comm System	KTR 908 / KFS 598 A
VHF AM / Comm System, 2nd system	KTR 908 / KFS 598 A
Comm. Control System, 2 stations + Intercom Select Panel	AS 3100-12 (BECKER)
VOR / ILS / MKR Navigation System with CDI	KNR 634 A / KFS 564 A / KA 35 A / KI 204
VOR / ILS / MKR Navigation System, with CDI, 2nd System	KNR 634 A / KFS 564 A / KI 204
Distance Measuring Equipment (D.M.E.)	KDM 706 A / KDI 572 *)
Automatic Direction Finder (A.D.F.)	KDF 806 / KFS 586 A
Transponder	KXP 756 / KFS 576 A
Radar altimeter	KRA 405 B / KNI 416
Battery pack for stand-by horizon	PS-835 C
2ea radio master switches	Special ECD
Weight supplement (without equipment kit)	40.0 kg

Note: Required equipment kit for single/dual pilot IFR-operations refer to para 6.6

**6. Minimum Items of Equipment for Dual/Single Pilot IFR Certification - Civil Use
(with AFCS and EFS 40, Allied Signal Gold Crown)**

Designation	Solution 8
EFS 50	SG 465 / 2 ED 511 A / CP 467 / SU 463
EFS 50, 2nd System	SG 465 / 2 ED 511 A / CP 467
VHF/AM Comm System	KTR 908 / KFS 598 A
VHF/AM Comm System, 2nd System	KTR 908 / KFS 598 A
Comm. Control System, 2 stations + Intercom Select Panel	BECKER AS 3100-12 (BECKER)
VOR / ILS / MB Navigation System	KNR 634 A / KFS 564 A
VOR / ILS / MB Navigation System, 2nd System	KNR 634 A / KFS 564 A
Distance Measuring Equipment (D.M.E.)	DMS 44 A
Automatic Direction Finder (A.D.F.)	KDF 806 / KFS 586 A
Transponder	KXP 756 / KFS 576 A
Radar altimeter	KRA 405 B
Battery pack for stand-by horizon	PS-835 C
2ea radio master switches	Special ECD
Weight supplement (without equipment kit)	62.1 kg

Note: Required equipment kit for single/dual pilot IFR-operations refer to para 6.6

6.6 Associated Avionic Package Equipment

For the proposed Dual Pilot IFR Solutions (Solution 3-5) the following Optional Equipment is necessary:

- BK-064a Dual Pilot Operation kit
- BK-092 2nd landing Light
- BK-188 Cockpit Storage kit
- BK-214 CSAS
- BK-Invert-01 2nd static inverter
- BK-181 Avionics compartment (not for Solution 3)

For the proposed Dual Pilot IFR Solutions, with DAFCS (Solution 6-8) the following Optional Equipment is necessary:

- BK-064a Dual Pilot Operation kit
- BK-092 2nd landing Light
- BK-171 Battery relocation
- BK-188 Cockpit Storage kit
- BK-215 c Autopilot with coupled Flight Director (DAFCS)
- BK-Invert-01 2nd static inverter
- BK-181 Avionics compartment (not for Solution 5)
- Replacement of pilot and copilot encoding altimeter 5035 P2 P42 by 10420-1196 E

6.7 EQUIPMENT THAT CAN BE ADDED DEPENDING ON THE OPERATIONAL NEEDS

The additional equipment marked with "X" is possible for the solutions indicated in the first line of the matrix.

Equipment	Type	Weight (kg)	1	2	3	4	5	6	7	8
2" Stand-by Horizon	AI 804 (B.F GOODRICH)		X	X	X	X	X	X	X	X
Automatic Direction Finder	KDF 806 / KFS 586 A	4.2		X						
Automatic Direction Finder / RMI	KR 87 / KI 229	4.0	X							
Automatic Direction Finder / RM incl. Adapter	KR 87 / KDA 692							X		
CDI	KI 204	1.0	X	X	X	X	X	X	X	X
Color Weather Radar 1)	RDR 2000	15.0	X	X	X	X	X	X	X	X
Color Weather Radar 1)	RDR 2100	15.0	X	X	X	X	X	X	X	X
Color Weather Radar 1)	RDR 1400 C	20.0	X	X	X	X	X	X	X	X
Comm. Control System, 2nd station	AS 3100-12 (BECKER)	1.0	X	X						
Comm. Control System, 3rd station	AS 3100-12 (BECKER)	1.3			X	X	X	X	X	X
Distance Measuring Equipment	KN 63 / KDI 572	2.2	X							
Distance Measuring Equipment	KDM 706 A / KDI 572;KPI 553 A instead of KPI 552 / KDI 572	3.3		X						
Emergency Locator Transmitter	ELT 100 HM (ARTEX) or JE 2 (JOLLIET)	2.2	X	X	X	X	X	X	X	X
GPS Course Deviation Indicator	802100 (ETS / DAC)	0.3	X	X	X	X	X	X	X	X
GPS Navigation System	2000 Approach + (TRIMBLE)	2.9	X	X	X	X	X	X	X	X
GPS Navigation System	2101 Approach + (TRIMBLE)	2.9	X	X	X	X	X	X	X	X
GPS Navigation System	2101 I/O Approach + (TRIMBLE)	2.9		X		X	X		X	X
GPS Navigation System	KLN 90 B	3.8	X	X	X	X	X	X	X	X
GPS Navigation System	KLN 900	3.5		X		X	X		X	X
HF Communication System	KHF 990 / KFS 594	13.5	X	X	X	X	X	X	X	X
IC Amplifier	IC 3100-4 (BECKER)	1.5	X	X	X	X	X	X	X	X
Marker Beacon	KR 21	0.8	X							
Moving Map Kneeboard	DKG 3 (DORNIER, basic version)	on request	X	X	X	X	X	X	X	X
Moving Map System	DKG 4 (DORNIER) Map generator + control unit + options	on request		X	X	X	X	X	X	X
Moving Map System (not compatible with Color Weather Radar)	Euro Nav III (EURO AVIONICS): Computer + display unit +control unit + switchbox + GPS-vedtor map of customer´s county	on request		X	X	X	X	X	X	X
Radar Altimeter	KRA 405 B / KNI 416	3.6	X	X	X	X	X	X	X	X
Stormscope	WX 1000 + (B.F.GOODRICH)	6.1	X	X	X	X	X	X	X	X
Stormscope	WX 1000 + E (B.F. GOODRICH)	6.1				X	X		X	X
Tactical FM Radio	Ascom FuG 8 or FuG 9		X	X	X	X	X	X	X	X
Tactical FM Radio	Flexcomm II	on request	X	X	X	X	X	X	X	X
Tactical FM Radio	GM 900 or GM 2100	on request	X	X	X	X	X	X	X	X
Tactical FM Radio	Tac / Com II	on request	X	X	X	X	X	X	X	X
Tactical FM Radio	AEG Teledux 9	on request	X	X	X	X	X	X	X	X

1) installation of radar radome BK-170a is necessary

**6.7 EQUIPMENT THAT CAN BE ADDED DEPENDING ON THE OPERATIONAL NEEDS
(continued)**

Equipment	Type	Weight (kg)	1	2	3	4	5	6	7	8
Transponder - Mode S	KT 70 A (instead of KT 71)	± 0	X		X			X		
Transponder - Mode S	MST 67 A / KFS 578 A instead of KXP 756 / KFS 576 A	+ 2.5		X		X	X		X	X
UHF / AM Transceiver "Subject to Export Authorization"	AN / ARC 164 (MAGNAVOX)	on request	X	X	X	X	X	X	X	X
VHF AM / Comm. System	KY 196 A - 30	1.8	X							
VHF AM / Comm. System, 2nd system	KTR 908 / KFS 598 A	2.4		X						

7. MAIN PERFORMANCE

The performance figures shown below are guaranteed minimum performance data.

Unless otherwise specified, they are for the aircraft in "clean" configuration in zero wind, sea level, and standard atmosphere conditions.

Take-off weight	kg lb	2,800	3,000	3,200	3,350	
		6,173	6,615	7,055	7,385	
■ VNE	km/ hr	278	278	278	259	
	mph	173	173	173	161	
	kts	150	150	150	140	
■ Fast cruise speed	km/hr	252	250	248	246	
	mph	157	155	154	153	
	kts	136	135	134	133	
■ Fuel consumption at fast cruise speed	kg/hr	260	260	260	260	
	lb/hr	573	573	573	573	
■ Economical cruise speed	km/hr	237	235	233	231	
	mph	147	146	145	144	
	kts	128	127	126	125	
■ Fuel consumption at economical cruise speed	kg/hr	239	240	242	243	
	lb/hr	527	529	535	536	
■ Fuel consumption at 65 KIAS	kg/hr	188	193	198	202	
	lb/hr	415	426	437	445	
■ Rate-of-climb at 65 KIAS - TOP	m/sec.	11.7	10.9	9.8	9.0	
	ft/min.	2,300	2,150	1,925	1,765	
■ Maximum range (without fuel reserve, at economical cruise speed)	▪ with standard fuel	km	555	550	545	540
		st.m	345	342	339	336
		n.m	300	297	294	292
	• plus long range fuel tank	km	715	710	705	700
		st.m	444	441	438	435
		n.m	386	383	381	378
	• plus 1 external fuel tank	km	655	650	645	640
		st.m	407	404	401	398
		n.m	354	351	348	346
	• plus 2 external fuel tanks	km	745	740	735	730
		st.m	463	460	457	454
		n.m	402	400	397	394

PERFORMANCE ON 2 ENGINES (continued)

All-up weight	kg lb	2,800	3,000	3,200	3,350
		6,173	6,615	7,055	7,385
■ Maximum endurance (without fuel reserve, at 65 KIAS)					
▪ with standard fuel tanks	hr	3.1	3.0	2.9	2.9
• plus long range fuel tank	hr	4.0	3.9	3.8	3.7
• plus 1 external fuel tank	hr	3.7	3.6	3.6	3.5
• plus 2 external fuel tanks	hr	4.4	4.3	4.2	4.1
■ Hover ceiling I.G.E. at take-off power, (3 ft), zero wind or headwind					
▪ ISA	m ft	4,390 14,400	3,690 12,100	3,050 10,000	2,530 8,300
▪ ISA + 20° C	m ft	3,690 12,100	2,990 9,800	2,345 7,700	1,845 6,050
■ Hover ceiling I.G.E. at take-off power, (3 ft), with 20 kts sidewind					
▪ ISA	m ft	3,855 12,650	3,200 10,500	2,530 8,300	1,920 6,300
▪ ISA + 20° C	m ft	3,170 10,400	2,515 8,250	1,845 6,050	1,235 4,050
■ Hover ceiling O.G.E at take-off power (104 % mode)					
▪ ISA	m ft	4,085 13,400	3,520 11,550	3,000 9,850	1,480 4,850
▪ ISA + 20° C	m ft	3,640 11,950	2,970 9,750	2,286 7,500	1,100 3,600
■ Service ceiling at MCP (climb reserve: Vz = 1,0 m/sec. - 200 ft/min.)					
▪ ISA	m ft	5,485 18,000	5,485 18,000	5,485 18,000	5,090 16,700
▪ ISA + 20° C	m ft	5,485 18,000	5,485 18,000	5,060 16,600	4,700 15,400

In external load carrying mission at maximum gross-weight of 3,500 kg (7,716 lb)

- Hover ceiling O.G.E. at take-off power (100 %)
 - ISA 460 m
 1,500 ft
 - ISA + 20° C 0 m
 0 ft

PERFORMANCE ON 1 ENGINE

All-up weight	kg lb	2,800	3,000	3,200	3,350
		6,173	6,615	7,055	7,385
<ul style="list-style-type: none"> ■ Rate of climb at 30 min power (OEI - MCP) 	m/sec. ft/min.	3.5 695	2.6 505	1.7 340	1.2 235
<ul style="list-style-type: none"> ■ Service ceiling (climb reserve: 0,5 m/sec. - 100 ft/min.) at 30 min power (OEI - MCP) <ul style="list-style-type: none"> ▪ ISA 	m ft	3,855 12,650	3,290 10,800	2,715 8,995	2,025 6,650
<ul style="list-style-type: none"> <ul style="list-style-type: none"> ▪ ISA + 20° C 	m ft	3,290 10,800	2,665 8,750	2,025 6,650	1,540 5,050
<ul style="list-style-type: none"> ■ Max. temperature for Cat. A take-off from clear heliport at sea level 	°C	+ 50	+ 50	+ 48	+43

		ISA	ISA + 20° C
Hover gross weight at 2.5 min power at sea level			
<ul style="list-style-type: none"> ■ Hover O.G.E. 	kg lb	2,770 6,107	2,550 5,622
<ul style="list-style-type: none"> ■ Hover O.G.E., 10 kts head wind 	kg lb	2,895 6,382	2,670 5,886
<ul style="list-style-type: none"> ■ Hover I.G.E. (3 ft) 	kg lb	3,020 6,658	2,790 6,151

Operating limitations

The aircraft is cleared to operate within the following altitude and temperature limitations :

- Maximum altitude
 - Flight 18,000 ft pressure altitude
 - Cat. B take-off and landing 18,000 ft density altitude or 18,000 ft pressure altitude (whichever is less)
 - Cat. A take-off and landing (clear heliport) 13,000 ft density altitude
- Maximum temperature ISA + 35° C limited to + 50° C
- Minimum temperature
 - 35° C (basic)
 - 45° C (with cold weather kit installed)

TAKE-OFF WEIGHT IN HOVER I.G.E. (3 ft)
 on 2 engines at maximum take-off power
 and variable rotorspeed (norm mode)
 (no wind or headwind)

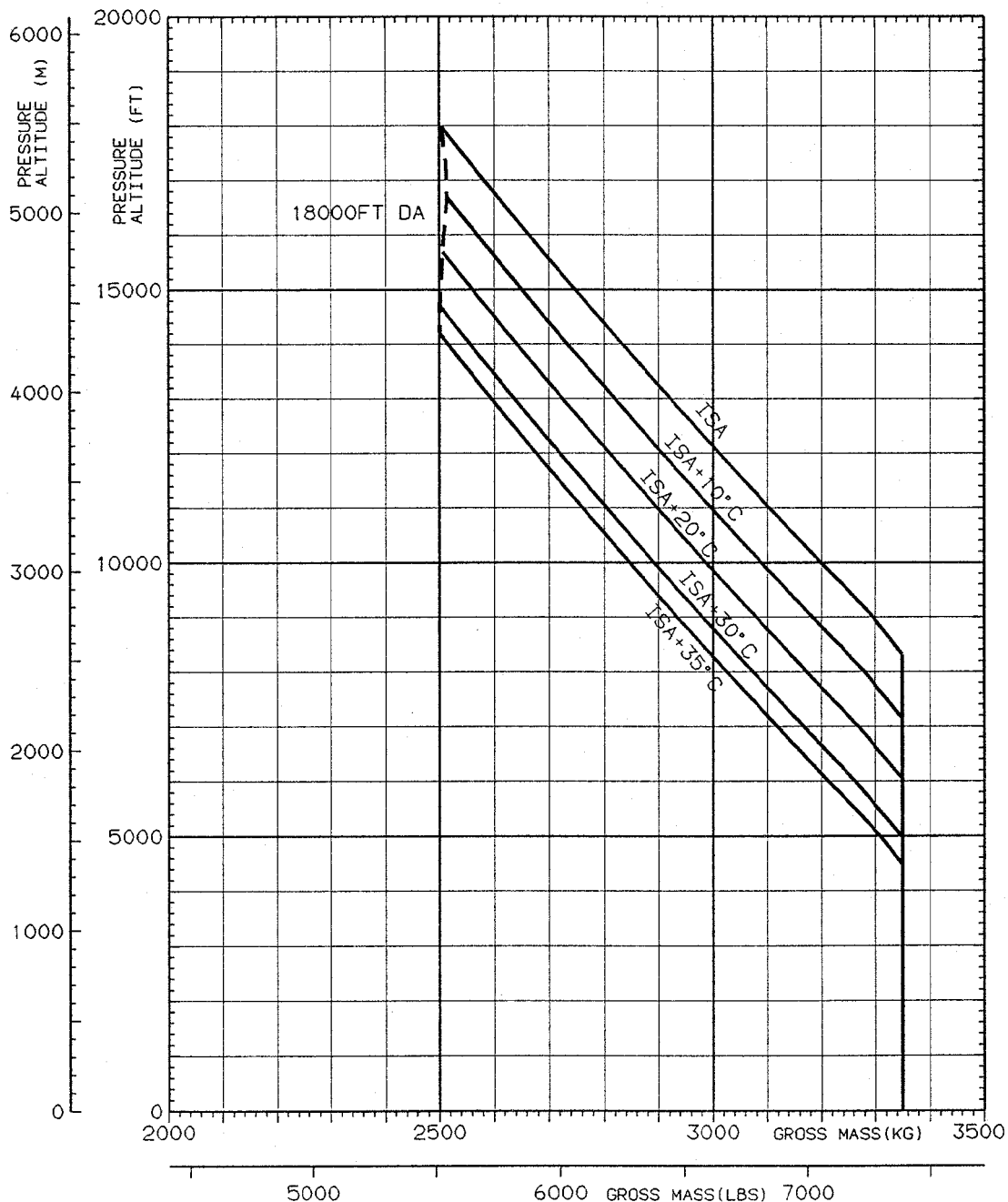

TAKE-OFF WEIGHT IN HOVER I.G.E. (3 ft)
 on 2 engines at maximum take-off power
 and variable rotorspeed (norm mode)
 (with 20 kts crosswind)

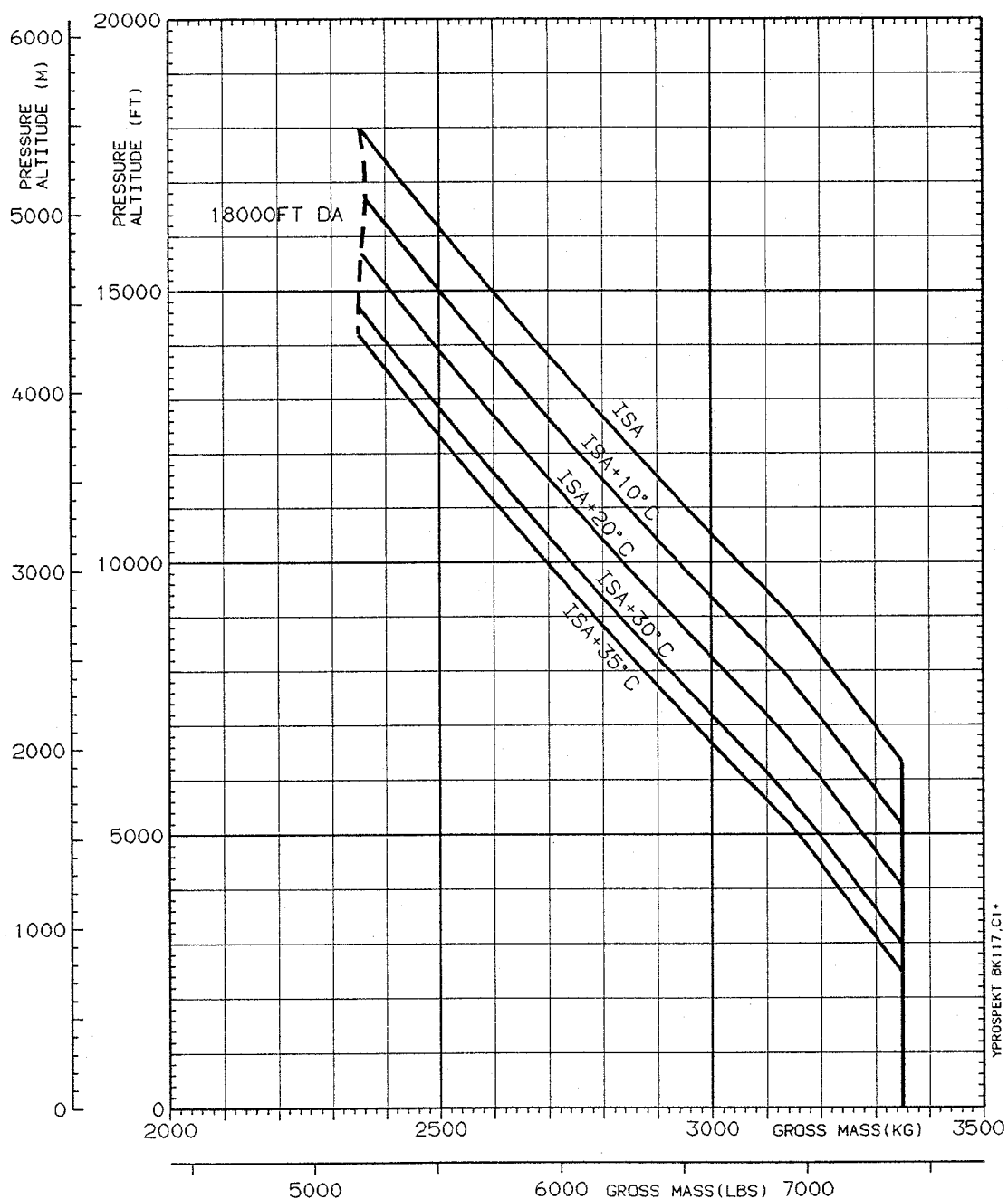

YPROSPEKT BK117.C1*

HOVER CEILING O.G.E.
on 2 engines at maximum take-off power
(104 % mode)

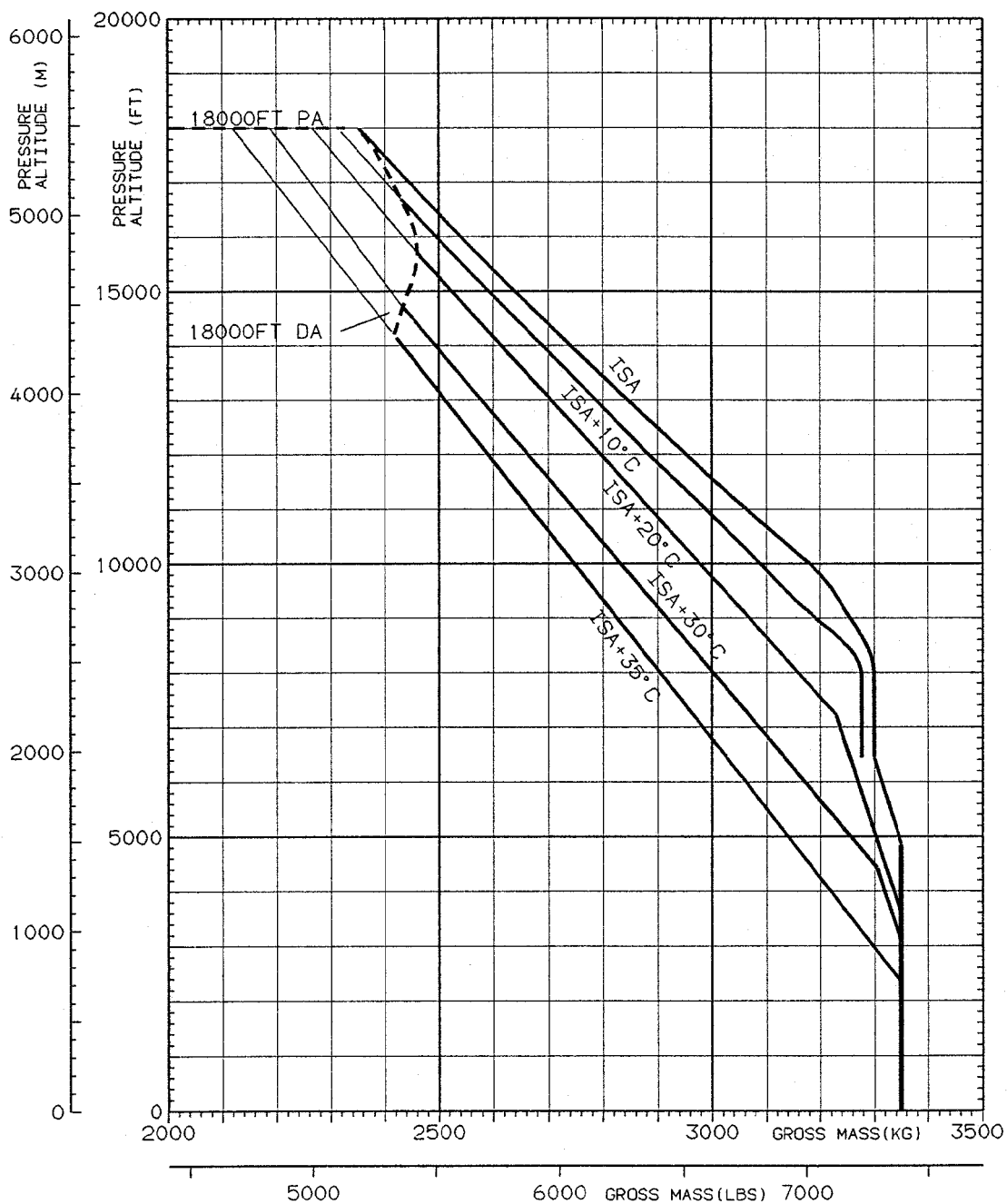

HOVER CEILING O.G.E.
 on 1 engine (2,5 min O.E.I. power)
 100 % rotorspeed (manual mode)

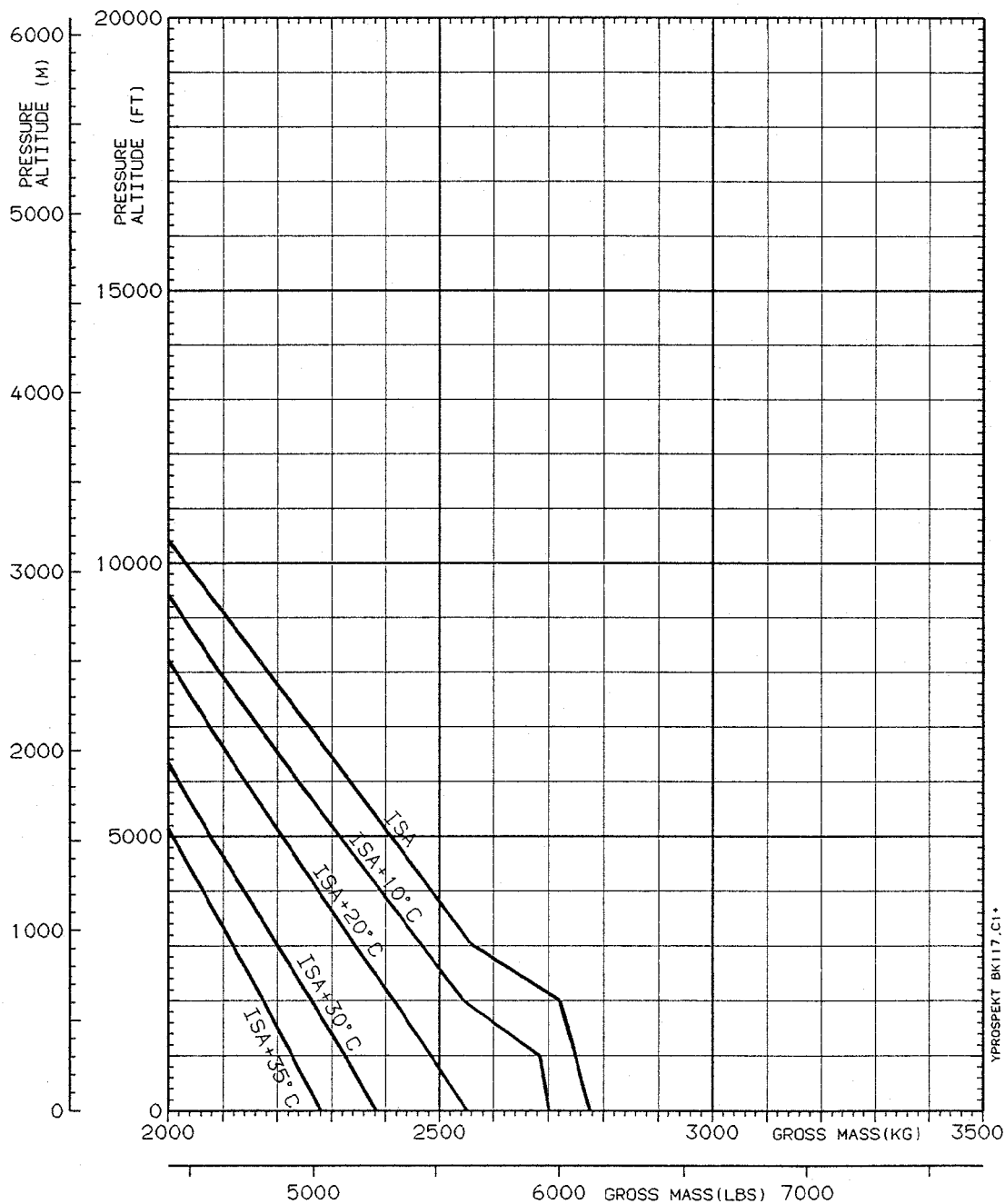

YPROSPEKT BK117.C1*

HOVER CEILING I.G.E.
 on 1 engine (2,5 min. O.E.I. power) and
 100 % rotorspeed (manual mode)

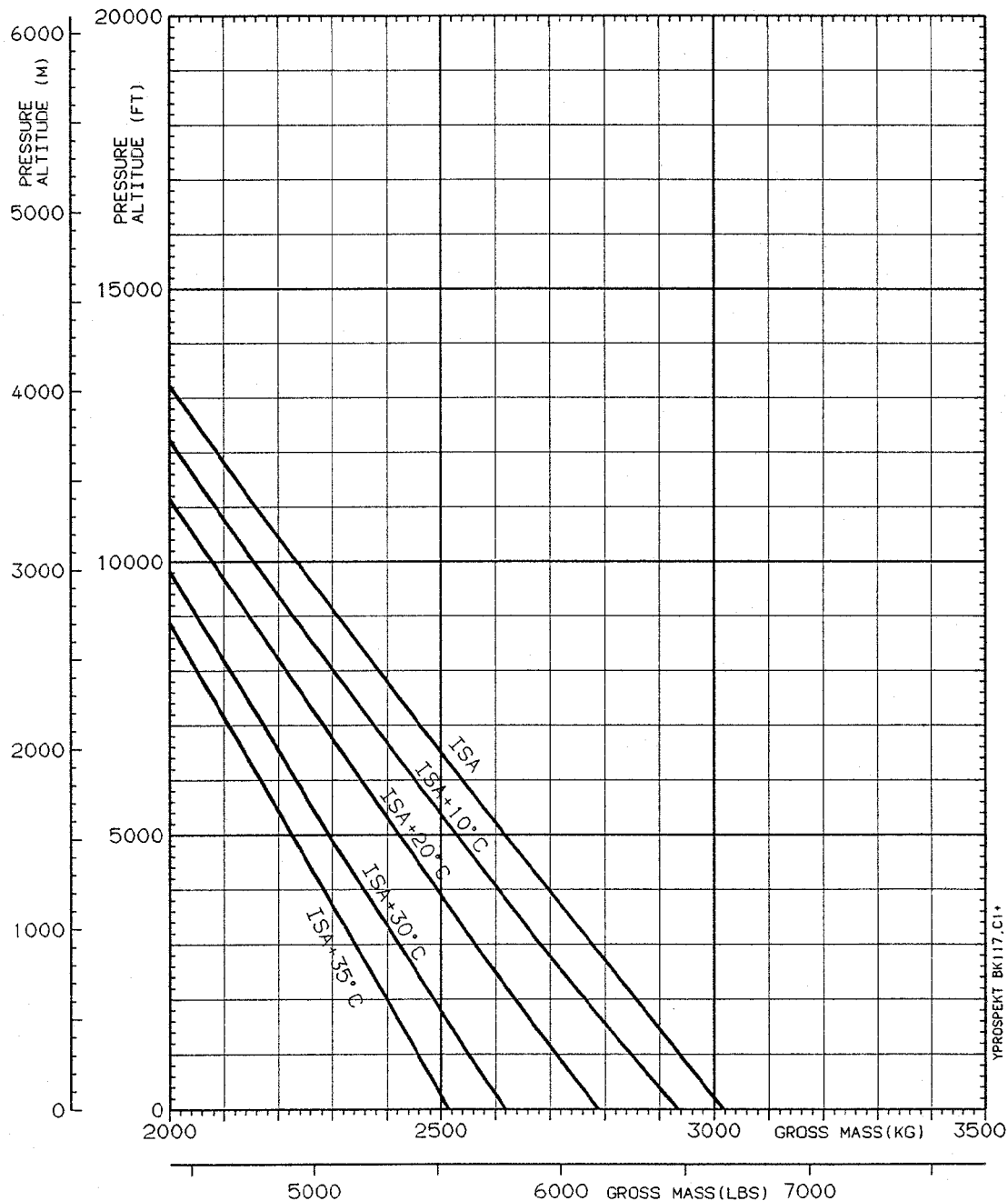

YPROSPEKT BK117.C1*

SERVICE CEILING
 on 1 engine at maximum continuous power
 with 100 ft/min. climb reserve

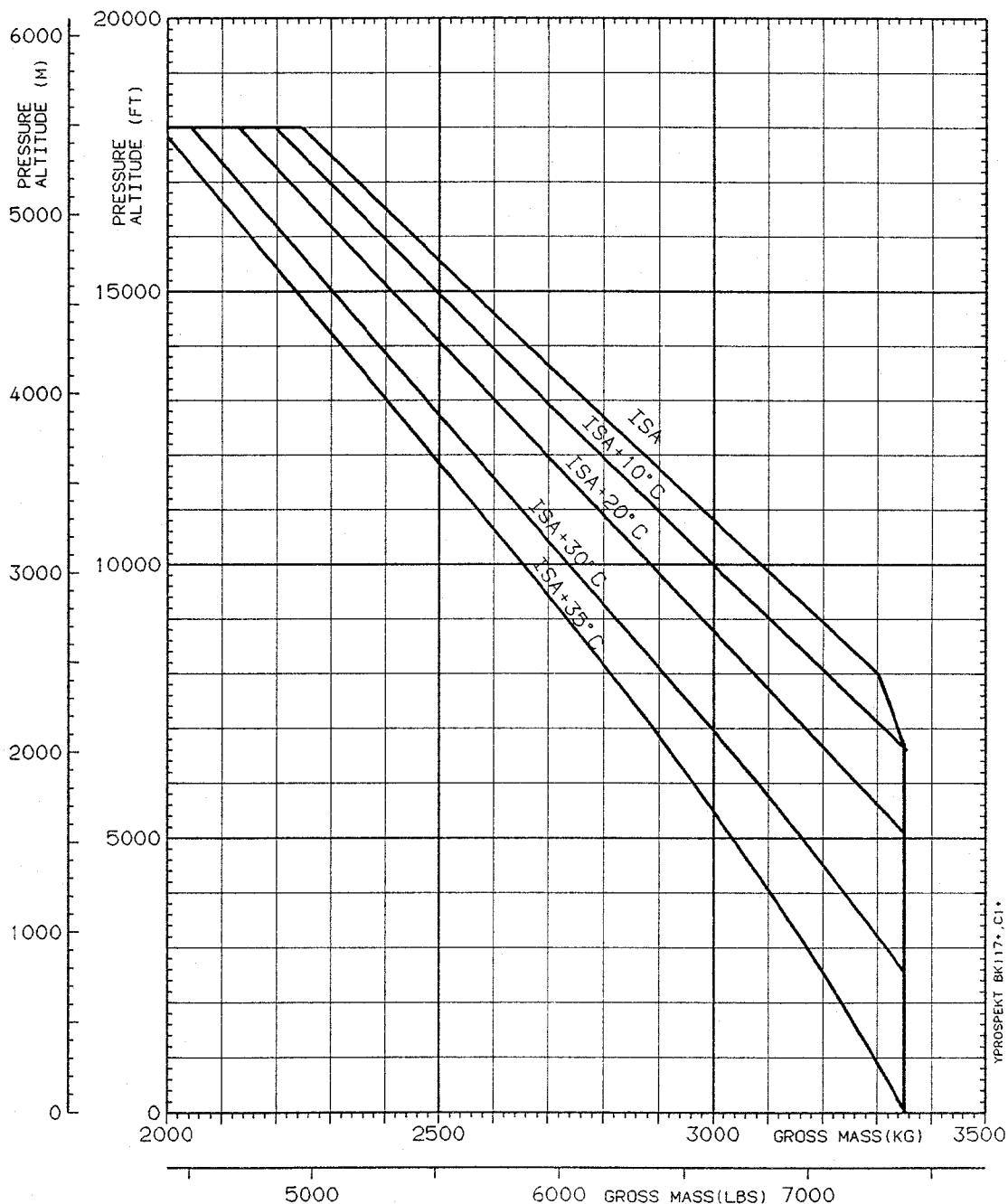

YPROSPEKT BK117-C1*

FAST CRUISE SPEED

on 2 engines at maximum continuous power
(ISA)

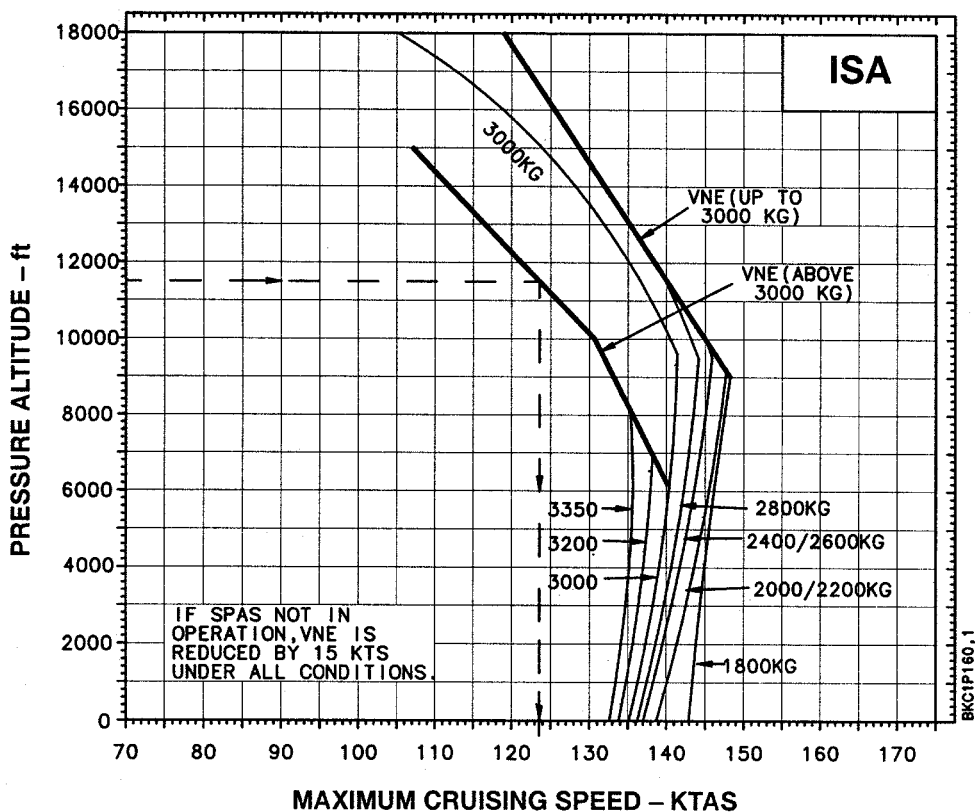

RATE OF CLIMB
 on 2 engines (TOP) at best climb speed
 at maximum gross weight : 3,350 kg

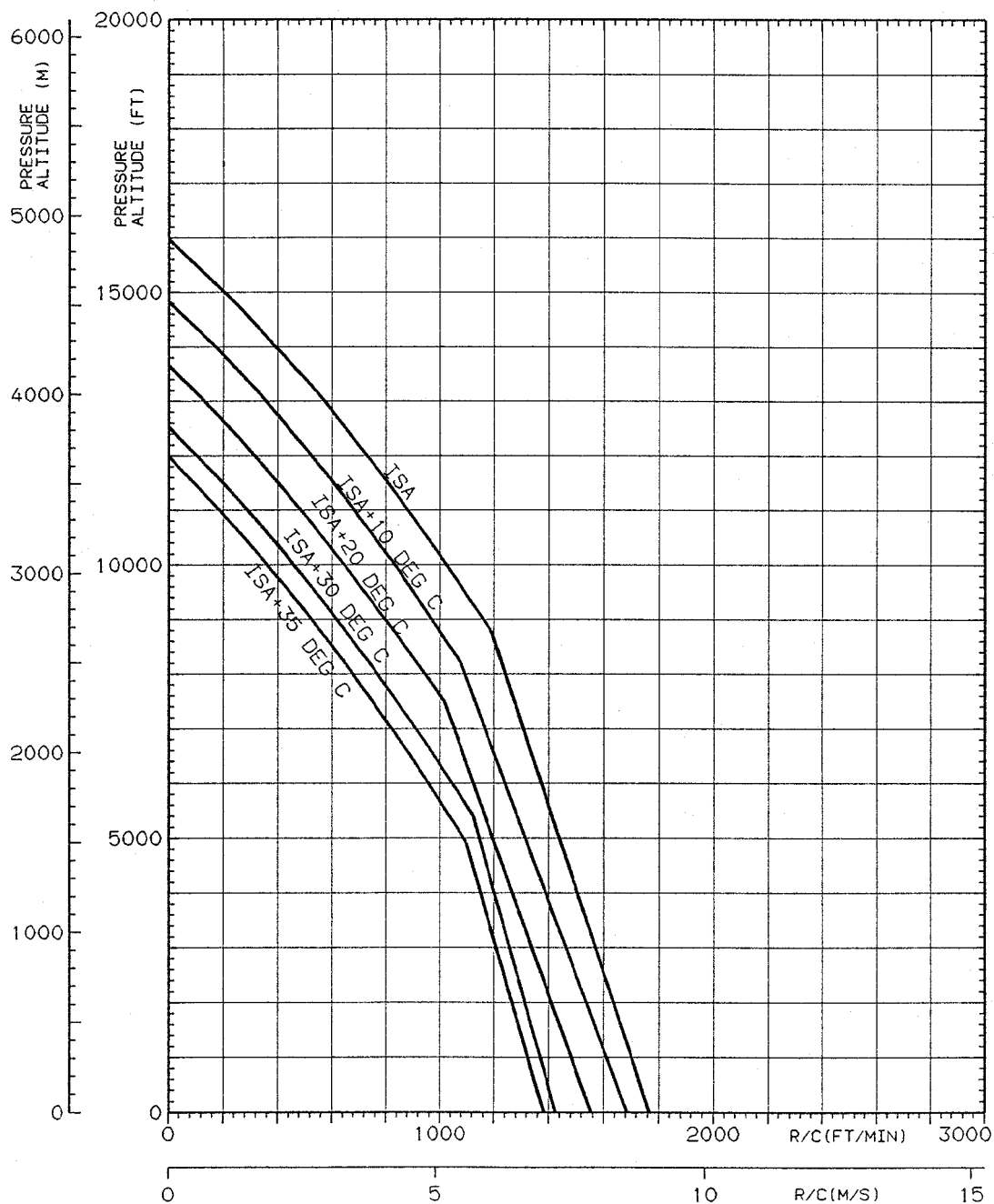

MAXIMUM GROSS WEIGHT on take-off from clear heliport, Cat. A

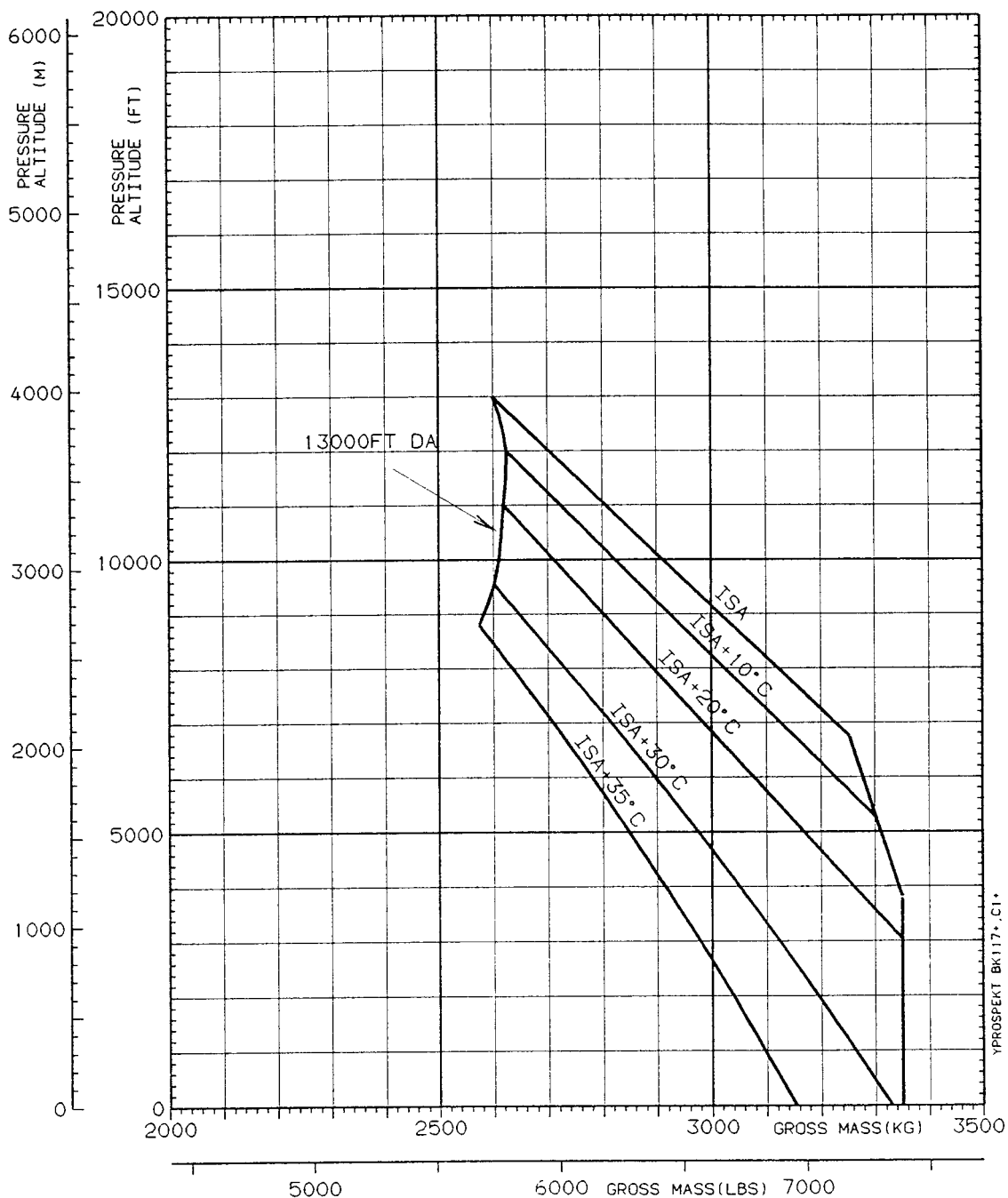

**POWER REQUIRED TORQUE VERSUS SPEED
(AEO)**

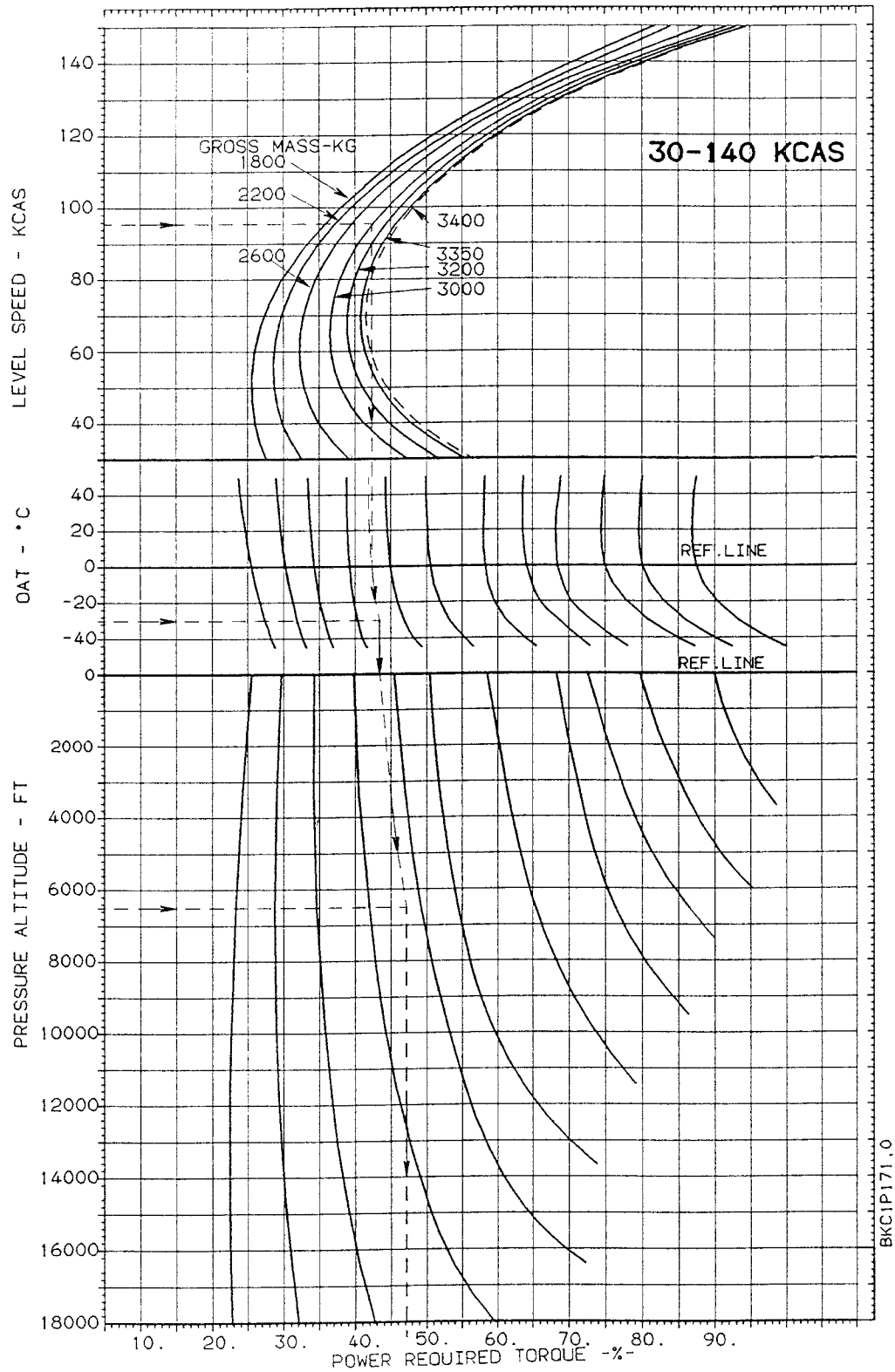

FUEL CONSUMPTION VERSUS TORQUE (AEO)

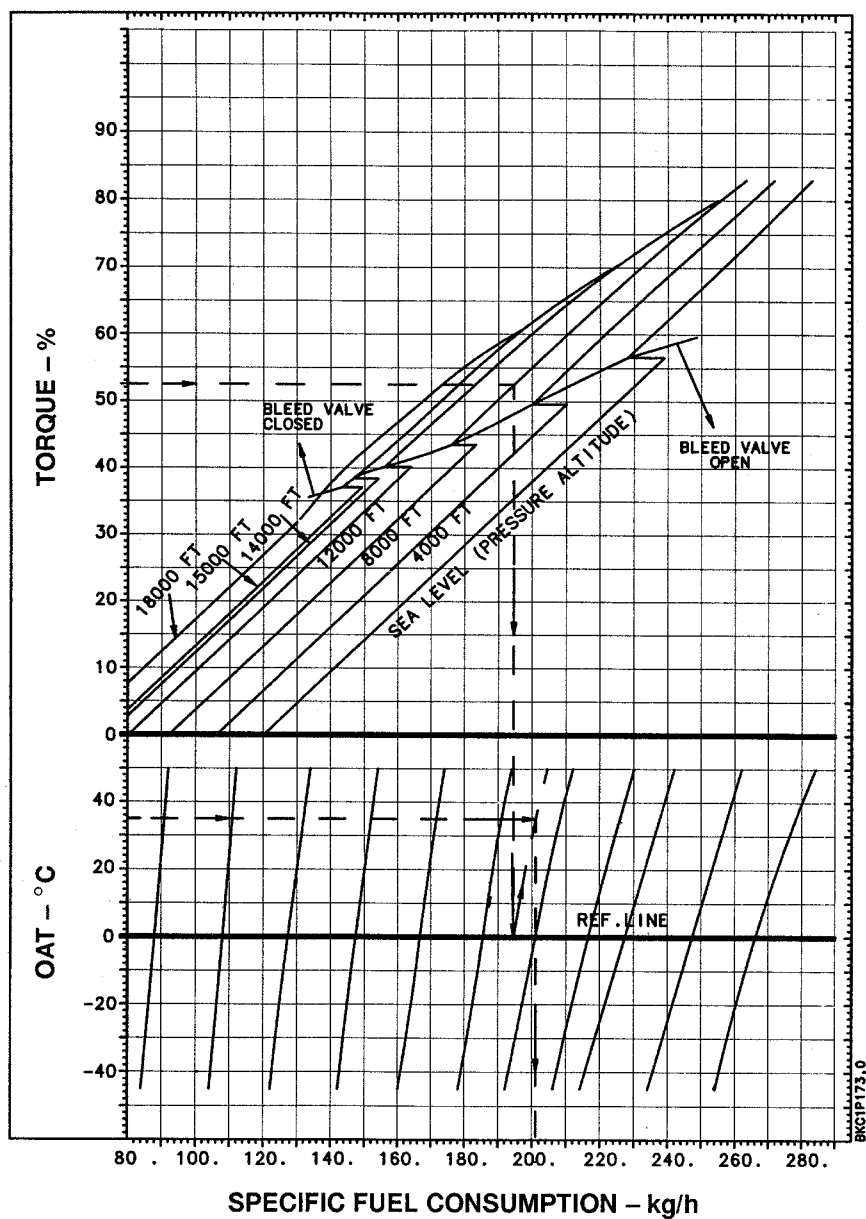

**PAYLOAD - RANGE
AT ECONOMICAL CRUISE SPEED
(ISA, Sea Level, No reserve)**

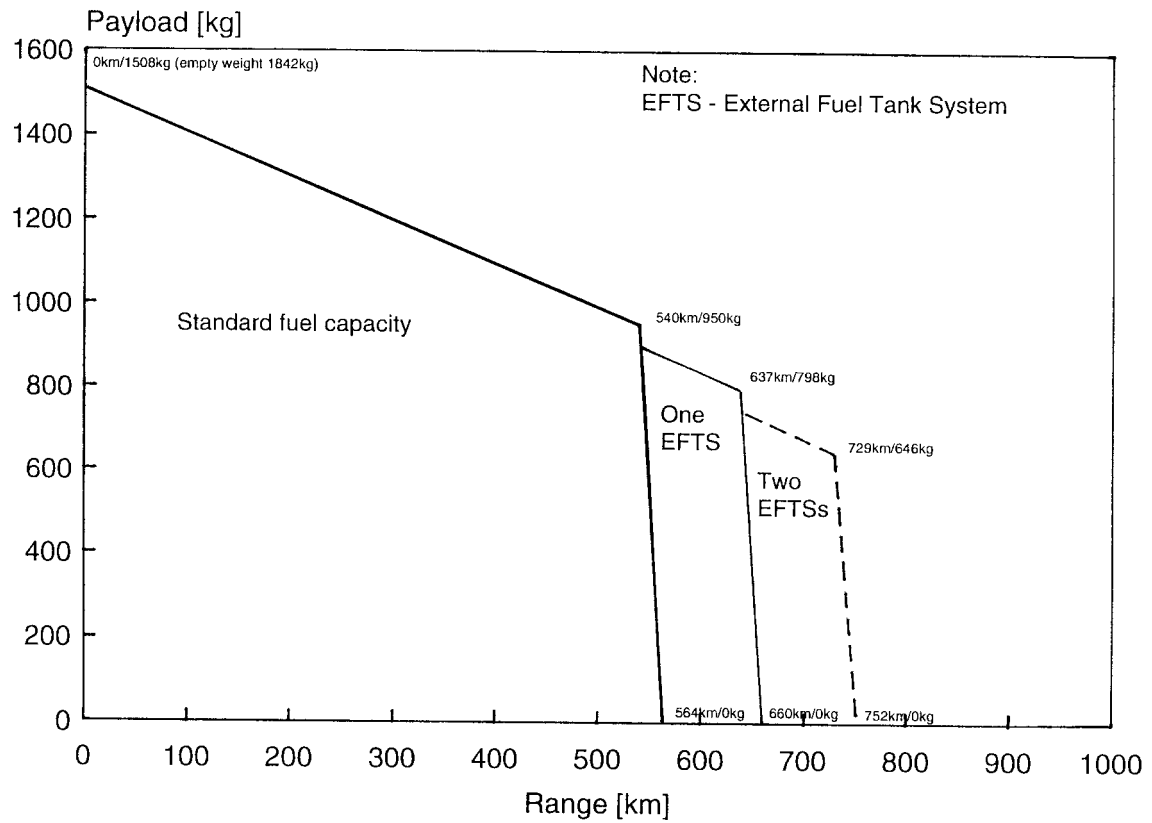

Operational empty weight incl. pilot (77kg): 1842kg

intentionally left blank